

CS100 polymer concrete cable duct with 4-bolt solid iron lids

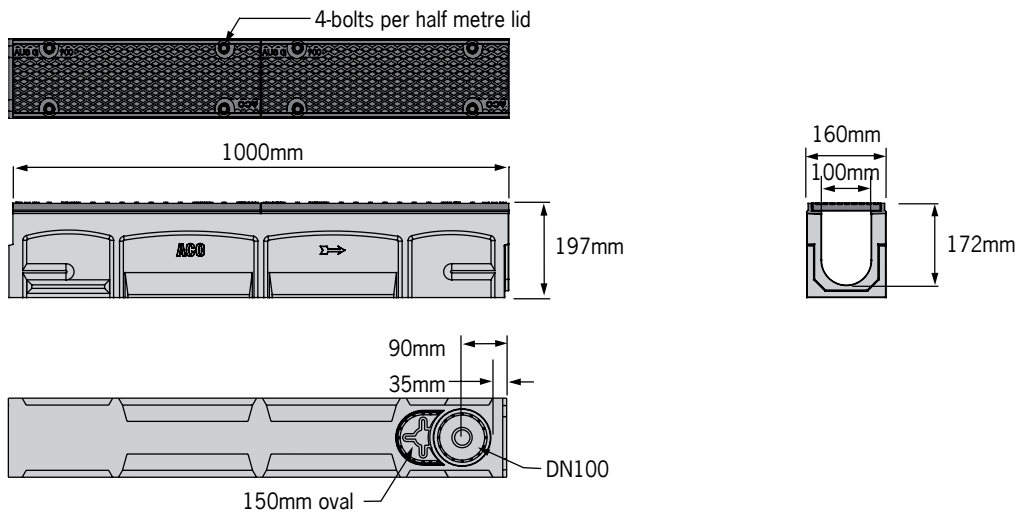

One metre duct



End cap

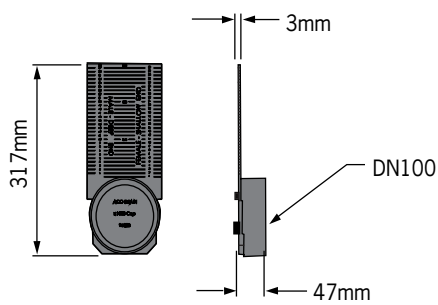

ACO Specification Information

CS100 polymer concrete cable duct with 4-bolt solid iron lids



ACO Specification Information

Cable duct

Description	Part No.	Weight (kg)	
		cover	total
CS010 polymer concrete duct with ductile iron lids - 1m	02813	7	39
CS100 End cap	90396	0.2	

Notes

1. CS100 duct is sold complete, with duct and lids.
2. Preformed drill-out for DN100 or DN150 oval to round pipe on underside of duct.

Specifications

General

The cable duct shall be ACO Cablemate CS100 Class G solid ductile iron 4-bolt lids as manufactured by ACO Pty Ltd.

Materials

Duct system bodies are manufactured from polymer concrete with minimum properties as follows:

Electrical resistivity 1 x 10<sup>8</sup> Ω /sq  
 Compressive strength: 96MPa  
 Flexural strength: 27MPa  
 Water absorption 0.07%

Frost proof / Salt proof

Dilute acid and alkali resistant

Surface burn characteristics of the material shall comply with UL 723 IP ratings up to IP4X (AS 60529) - enclosure protection against ingress

The nominal clear opening shall be 100mm with overall width of 160mm. Modular units shall be manufactured with neutral invert and have a wall thickness of at least 16mm. Each unit will feature a full radius in the duct bottom and a male to female interconnecting end profile. Units shall have horizontal cast in anchoring features on the outside wall to ensure maximum mechanical bond to the surrounding bedding material and pavement surface. The ductile iron edge rail will be integrally cast in by the manufacturer to ensure maximum homogeneity between polymer concrete body and edge rail.

Lids

Lids are manufactured from ductile iron compliant to (AS 3996 Class G) and offer IP4X (AS 60529) protection against ingress of foreign objects. Lids are locked in place with 4 qty M10 high tensile steel bolts with friction grip washers per half metre lid. After removal of lids there shall be uninterrupted access to the duct.

Installation

The cable duct system shall be installed in accordance with the manufacturer's installation instructions and recommendations.

ACO Pty Ltd  
 Australia  
 Ph: 1300 765 226  
 www.acoaus.com.au  
 sales@acoaus.com.au



© May 2023 ACO Pty Ltd. All reasonable care has been taken in compiling the information in this document. All recommendations and suggestions on the use of ACO products are made without guarantee since the conditions of use are beyond the control of the company. It is the customer's responsibility to ensure that each product is fit for its intended purpose and that the actual conditions are suitable. ACO Pty Ltd. pursues a policy of continuous product development and reserves the right to amend specifications without notice.