

J10C - ACO COVERCOM® SCEC (SL2) - concrete pit & steel lid

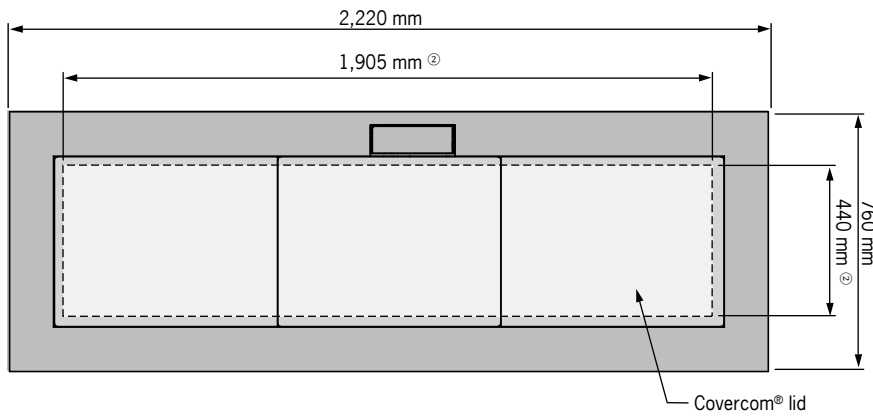

Cable pit - full body

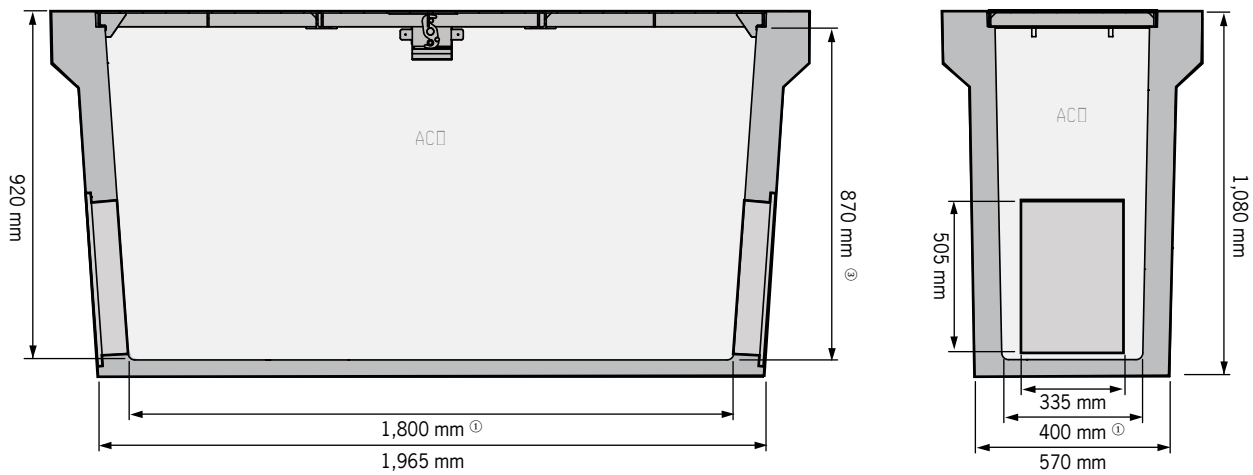

Cable pit - split body

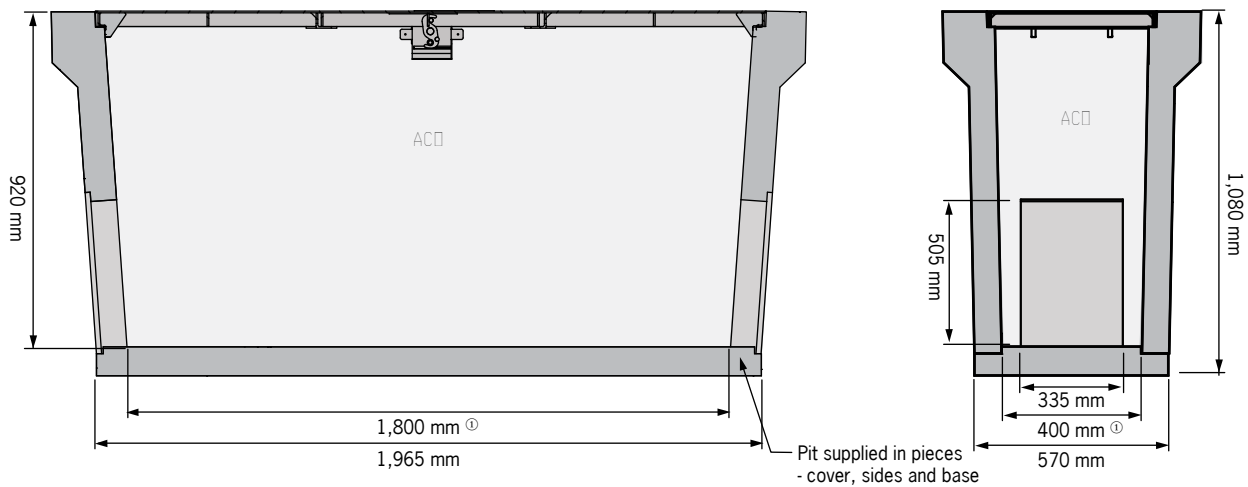

Key

- ① Clear working dimension at pit base
- ② Clear working dimension at pit opening
- ③ Clear working dimension beneath lid rebate

ACO Specification Information

ACO CABLEMATE

J10C - ACO COVERCOM® SCEC (SL2) - concrete pit & steel lid

Cable pit and riser

Description	Part No	Depth mm	Weight kg
J10C - ACO Covercom® - concrete pit & steel lid - full body	142259	1,080	1,260
J10C - ACO Covercom® - concrete pit & steel lid - split body	142260	1,080	1,260

Accessories & ancillary items

Description	Part No	Weight kg
Lid Lifting Tool	142232	0.5
ID Plates	On Enquiry	N/A
Route Marker Plates	On Enquiry	N/A
SCEC (SL3) Padlocks	On Enquiry	0.5
Swing Arm	On Enquiry	1
SCEC (SL2) approved precast concrete riser	On Enquiry	Variable

Specifications

General

The cable pit shall be ACO J10C COVERCOM® SCEC (SL2) - concrete pit & steel lid - full* / split* body as supplied by ACO Pty Ltd. or equal approved.

The pit is fully tested and assessed by Security Services who conduct tests on behalf of SCEC. SCEC have subsequently endorsed the lids and pits for the 'Protection of Classified Material'. This is contingent on the use of SCEC (SL3) padlocks to secure the lids.

Materials

The pit body shall be manufactured from steel reinforced cement concrete with:

Compressive strength: 40MPa

The nominal clear opening shall be 1,905mm x 440mm. Units shall be manufactured with an internal depth of 820mm.

Lid

The pit shall be covered with a locking steel lid. (SCEC SL2)

Installation

The cable pit shall be installed in accordance with the manufacturer's installation instructions and recommendations.

* delete as applicable

ACO Pty Ltd
Australia
 Ph: 1300 765 226
 www.acoaus.com.au
 sales@acoaus.com.au

© March 2018 ACO Pty Ltd. All reasonable care has been taken in compiling the information in this document. All recommendations and suggestions on the use of ACO products are made without guarantee since the conditions of use are beyond the control of the company. It is the customer's responsibility to ensure that each product is fit for its intended purpose and that the actual conditions are suitable. ACO Pty Ltd. pursues a policy of continuous product development and reserves the right to amend specifications without notice.

