

2. Installation

Once an appropriate location for a cable enclosure is determined and the conduit installed, preparations can be made for digging. Investigate whether other underground services exist.

In Australia, ACO recommends contacting **'Dial Before You Dig'** on 1100 or visiting their website at www.1100.com.au.

Designers and contractors must observe the regulations and codes of practice legislated by the electrical safety act and refer to ACO's standard installation drawings on pg 84.

Adverse ground conditions may require an increase in these dimensions and/or the addition of reinforcement. If in doubt, engineering advice should be sought.



a. Cable Pits

The following is a basic methodology for installing cable pits. If a degree of weather proofing is required, visit www.acoaus.com.au/cablemate for specific details.

1. Before installation, mark all conduit entries on pit walls.
2. Using holesaw of required size, cut out conduit entries. (See accessories pg 43).
3. Excavate greater than overall dimensions of the pit (refer to ACO's excavation guide for minimum dimensions - pg 82).
4. Remove all loose material from excavation. Level and compact base. ACO recommends compaction to 95% RDD (Relative Dry Density).
5. Install pit on a stiff wet concrete base with a minimum depth of 50mm. Higher load classes will require more concrete. A minimum concrete strength of 25MPa is recommended.

If using standard lids, ensure top of pit is level with the finished pavement level. If access covers are used, top of the pit must be set down beneath pavement. See standard installation drawings on pg 84.

6. Connect conduit to the pit, flush with inside wall so clear working area of the enclosure is not impeded. Conduits must have sharp edges removed from their internal surfaces.

If a bellmouth conduit fitting is required for drawing operations (pg 12), an appropriate sized hole should be cut and the bellmouth fitting is then epoxy glued onto the pit. The outside of pit should be reinforced around the bellmouth to ensure bellmouth/pit joint is not damaged when the cable is pulled.

ACO does not recommend the use of bellmouths for plastic pits.

7. For multiple conduit entries, ACO recommends a concrete haunch around all pipes to preserve pit rigidity. Minimum of 100mm concrete encasing is recommended around pipes and 200mm measured out from the pit wall (pg 20).
8. Seal pit and pipe connection with a proprietary sealant to prevent ingress of moisture and silt into pit during service.
9. Place lid into the rebate of pit before backfilling.

For Class A applications, backfill using sand or clean fill and lightly compact at 300mm increments. Note, if using plastic pits, do not over compact as this can lead to pit walls deforming.

For Class B applications, a concrete collar (at least) is required for paved, concreted and asphalted pavements with a minimum width and depth of 150mm. A minimum concrete strength of 25MPa is recommended.

For applications defined as Class C and above, concrete is required to encase all of the pit and access cover. In these instances, plastic pits are not recommended.

The visible/trafficable surface of the cement concrete surround (or pavement if asphalted to the edge of the pit/duct) must be finished flush with the pit/cover edge.

For installation illustrations for cable pit systems see pg 84 or for full installation details visit www.acoaus.com.au/cablemate

Supporting Information

2. Installation cont'd.

Access Cover Systems

If an access cover is used, it must be installed directly above the pit (pg 84)

- i. Form the rebate to size (to support the frame)
- ii. Position the access cover in rebate
- iii. Check the unit is level and does not rock
- iv. Pour & vibrate the concrete around the access cover and in the cover (if a concrete filled recessed cover is used)
- v. Level and finish concrete, lay pavers or pavement materials. **Urbanfil®/Pavermate®** covers are to be filled with concrete to a minimum depth of 45mm as concrete is integral to the strength of these covers. ACO does not recommend tiles deeper than 25mm in **Urbanfil®** covers and pavers more than 40mm deep in **Pavermate®** covers.
Recessed pan depths;
 - **Urbanfil®** - 85mm,
 - **Pavermate®** - 135mm,
 - **Rhinocast®** - either 12mm or 40mm dependent on steel edging height.
 Refer to notes beneath parts list table
- vi. Allow concrete to cure before removing cover – early removal may cause twisting of the frame

ACO sells a wide range of lifting keys dependent on the lid or cover type. Refer to accessories on pg 43.

For full installation details visit www.acoaus.com.au/cablemate

Pit Drainage

Conduits are generally installed with slope allowing water to drain into cable pits which are positioned at sag points along a cable route. Cable pits are generally not supplied with waterproof covers. To minimise the amount of standing water in the enclosure and in the conduits, a drainage point should be connected from the base of the pit to a suitable soakaway. All ACO cable pits are supplied with either a preformed hole (plastic pits) or a drillout hole in the base of polymer concrete pits. Holes are typically 25mm diameter or similar.

In some applications, telecommunication carriers may require up to a 300mm clearance below the lowest conduit entry for drainage purposes.

For landscaped applications, where only foot traffic is anticipated, it is recommended that at least 150mm of a gravel base is laid at the bottom of the pit. ACO recommends compaction no less than 60% RDD. The gravel acts as a drain and will help prevent the enclosure from sinking.

Conduits entering buildings should be installed to stop liquid from draining into the building. The simplest method is to make the exit end of the conduit (inside the building) higher than the external entry, while still applying sealing around the penetration of the building and within the pit wall.

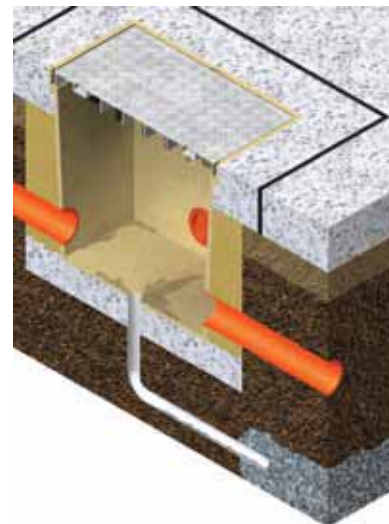

Pit drainage with soakaway.

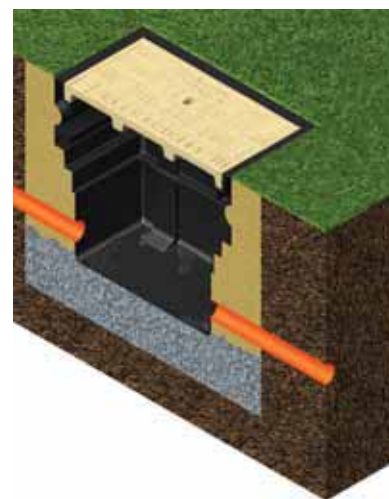

Landscape pit drainage.

b. Surface Cable Ducting

Ducting channels are installed in a continuous trench run, and are usually fully encased in concrete.

1. Excavate greater than the overall dimensions of the ducting channel (refer to ACO's excavation guide for minimum dimensions - pg 83).
2. Lay out ducting channels near the trench.
3. Ducting channels need to be supported at the correct height and held securely in place during the concrete pour.
4. To finish installation, pour concrete evenly either side of the trench. The top of the adjacent pavement should be above the lid level by approximately 3mm.

For installation illustrations for surface ducting systems see pg 84 or for full installation details visit www.acoaus.com.au/cablemate

c. Access Holes & Trunking Systems

Maintenance holes and cable trunking systems are usually fabricated on site or supplied as precast reinforced structures. ACO's access covers are designed to be installed above them in a multipart or trench run configuration (trench run multipart).

For a customised recommendation and full installation details contact ACO or visit www.acoaus.com.au/cablemate

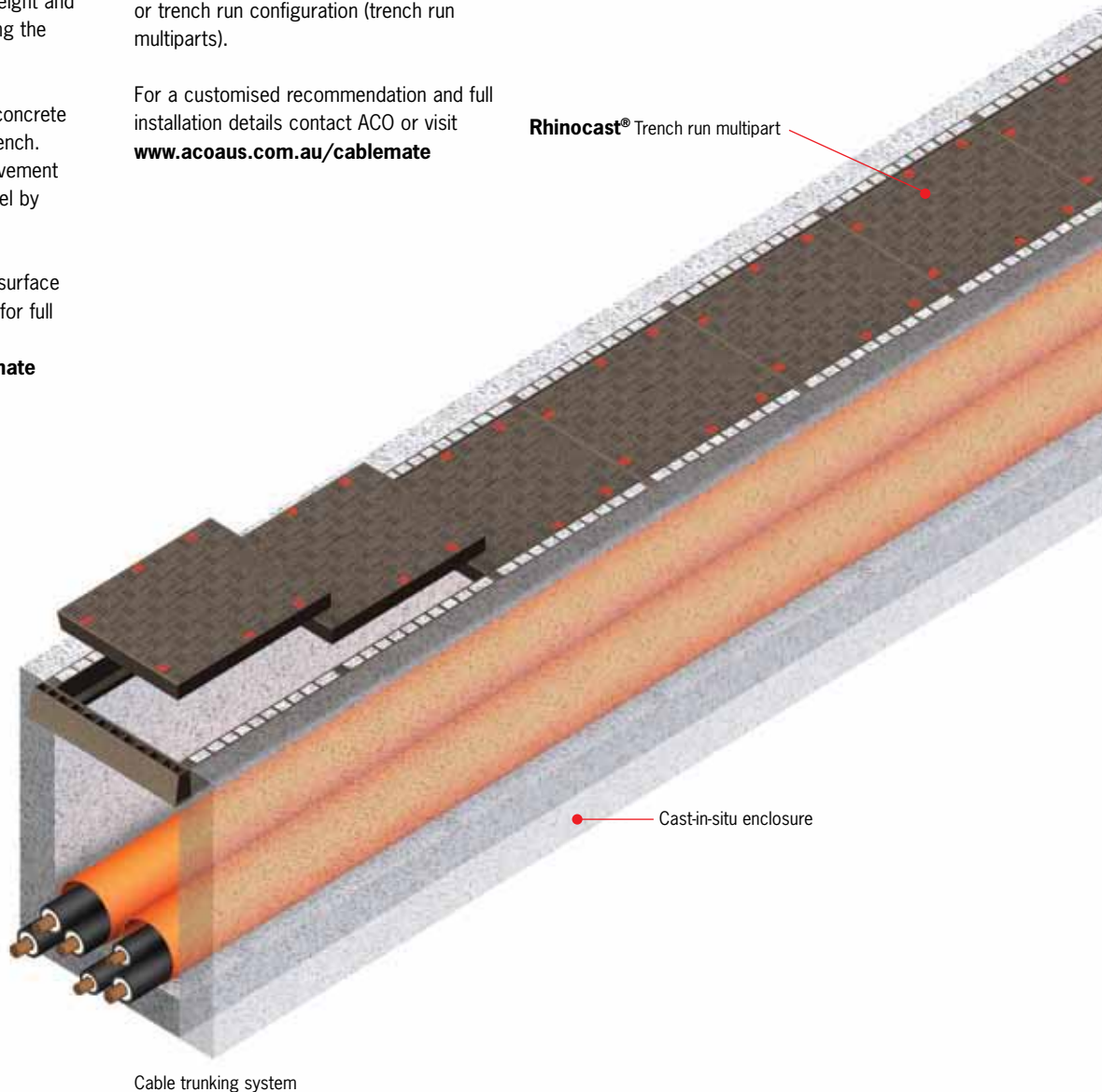

Supporting Information

3. Excavation Guide

Dimensions shown indicate minimum material to be excavated. (To be read in conjunction with pg 84/85).

Cable Pit & Lid Systems

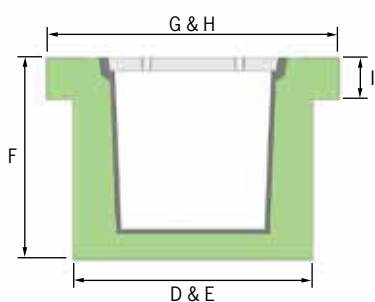
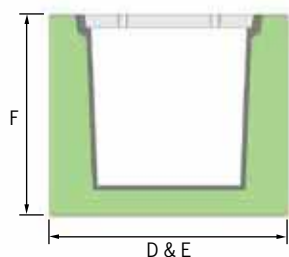

Class A & B (without collar)

Class A & B (with collar)

Polymer Concrete Pits ¹	Class A & B (without collar)			Class A & B (with collar)		
	D	E	F	G	H	I ²
Type 33	540	540	540	640	640	150
Type 45	710	710	700	810	810	150
Type 66	870	870	720	970	970	150
Type 66H	870	870	1020	970	970	150
Type 99	1210	1210	680	1310	1310	150
Type 52	710	420	540	810	520	150
Type 63	850	500	840	950	600	150
Type 95	1180	720	690	1280	820	150
Type 96	1200	900	720	1300	1000	150
Type 8	1600	780	1000	1700	880	150
Plastic Pits ¹	D	E	F	G	H	I ²
Type 1	720	440	500	820	540	150
Type 2	860	490	680	960	590	150
Type 3	770	540	630	870	640	150
Type 4	920	610	900	1020	710	150
Type 5	920	670	740	1020	770	150
Type 6	1580	770	770	1680	870	150
Type 7	1220	770	1250	1320	870	150
Type 8	1580	770	990	1680	870	150
Type 9	2240	770	990	2340	870	150
Type 43	630	630	710	730	730	150
Type 53	740	500	560	840	600	150
Type 55	760	760	610	860	860	150
Type 77	910	910	760	1010	1010	150

Class A & B (with collar)

Cable Pit with Access Cover Systems

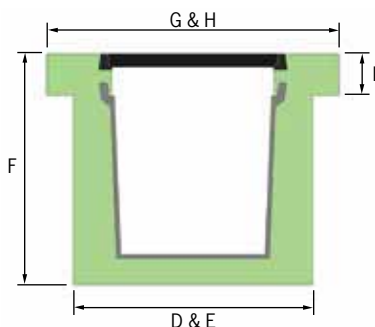

Polymer Concrete Pits ¹	Class A & B (with collar)			Class A & B (with collar)		
	D	E	F	G	H	I ²
Type 33	540	540	540	900	860	150
Type 45	710	710	700	900	880	150
Type 66	870	870	720	1050	1030	150
Type 66H	870	870	1020	1050	1030	150
Type 99	1210	1210	680	1350	1330	150
Type 52	710	420	540	900	860	150
Type 63	850	500	840	1050	860	150
Type 95	1180	720	690	1350	880	150
Type 96	1200	900	720	1350	1030	150
Type 8	1600	780	1000	1750	900	150
Plastic Pits ¹	D	E	F	G	H	I ²
Type 1	720	440	500	900	860	150
Type 2	860	490	680	1050	860	150
Type 3	770	540	630	1030	860	150
Type 4	920	610	900	1080	860	150
Type 5	920	670	740	1080	860	150
Type 6	1580	770	770	1750	900	150
Type 7	1220	770	1250	1600	1050	150
Type 8	1580	770	990	1750	900	150
Type 9	2240	770	990	2320	900	150
Type 55	760	760	610	1050	1030	150
Type 77	910	910	760	1200	1180	150

Cable Pit with Access Cover Systems

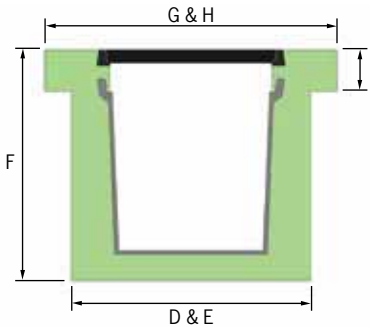

Class C & D (with collar)

Polymer Concrete Pits ¹	D	E	F	G	H	I ²
Type 33	640	640	590	970	970	200
Type 45	810	810	750	970	970	200
Type 66	970	970	770	1120	1120	200
Type 66H	970	970	1070	1120	1120	200
Type 99	1310	1310	730	1490	1420	200
Type 52	810	520	590	970	970	200
Type 63	950	600	890	1120	970	200
Type 95	1280	820	740	1420	970	200
Type 96	1300	1000	770	1420	1120	200
Type 8	1700	880	1050	1790	970	200

Class E, F & G (with collar)

Polymer Concrete Pits ¹	D	E	F	G	H	I ²
Type 33	740	740	640	1090	1090	250
Type 45	910	910	800	1090	1090	250
Type 66	1070	1070	820	1240	1240	250
Type 66H	1070	1070	1120	1240	1240	250
Type 99	1410	1410	780	1630	1540	250
Type 52	910	620	640	1090	1090	250
Type 63	1050	700	940	1240	1090	250
Type 95	1380	920	790	1540	1090	250
Type 96	1400	1100	820	1540	1240	250
Type 8	1800	980	1100	1930	1240	250

Surface Cable Ducting

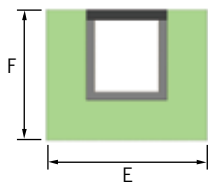

Class A & B Class C & D Class E, F & G

Ducts	E	F	E	F	E	F
CD1215	330	280	n/a	n/a	n/a	n/a
CD2127	410	390	n/a	n/a	n/a	n/a
CD3015	530	280	n/a	n/a	n/a	n/a
CS010	360	300	460	350	560	400
CS030	360	420	460	470	560	520
CS2000	460	390	560	440	660	490
CS2020	460	490	560	540	660	590
CS3000	560	500	660	550	760	600
CS3020	560	620	660	670	760	720

Note:

- If risers are used, add the following to the depth
 Type 43, 52, 53, 63 - riser not available
 Type 55 - 150 mm
 Type 1, 2, 77 (plastic riser) - 200 mm
 Type 7, 8, 9 - 400 mm
 Type 77 (polymer concrete riser) and all other pits - 300 mm
- If access covers are installed adjacent to pavers, increase excavation depth (I) by the depth of the paver and mortar. (See pg 84/85).