

Infill cover with T-frames

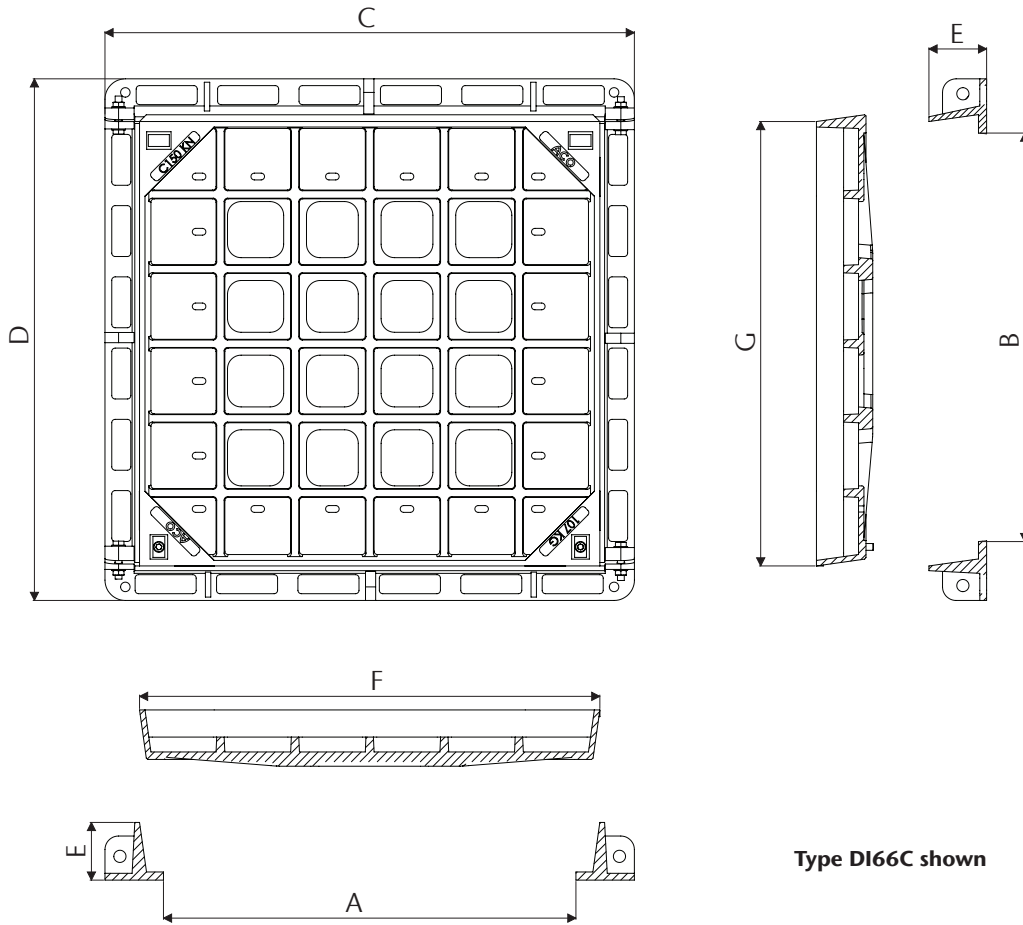

Type DI66C shown

Product Table

Type	Part No.	Clear Opening Width (A)	Clear Opening Length (B)	Overall Width (C)	Overall Length (D)	Overall Depth (E)	Cover Width (F)	Cover Length (G)	Cover Weight (kg)	Overall Weight (kg)
DI44C	142313	450	450	622	619	85	520	505	27	60
DI66C	142314	600	600	772	769	85	670	655	50	92
DI96C	142315	900	600	1072	769	85	970	655	75	119
DI99C	142316	900	900	1072	1069	85	970	955	98	155

Notes:

1. All dimensions in the table are nominal and are shown in millimeters.
2. Decorative Brass (BE) or Stainless Steel (SS) edging can be added - just specify BE or SS and height (12mm or 40mm) after part no.
3. Bolts are standard for each cover, specify Standard Locking bolts (SL) or security rated Security Bolts (SB) after part no.
4. If structural locking bolts are required, contact ACO.



ACO Specification Information

ACO ACCESS

Rhinocast - Single part infill iron access cover with T-frames - Class C

Accessories

Part No.	Description	Weight (kg)
84654	Rhinocast short handle lifters (pair)	3.60
84854	Rhinocast long handle lifters (pair)	8.10
73131	Sealing grease	4.40
84620	Rectangular red caps (short) for lifting key holes	-
84626	Circular red caps for locking bolt holes	-
77416	Brass plate (75 x 75mm) marked 'ELECTRICITY'	0.05
77402	Brass plate (75 x 75mm) marked 'COMMUNICATIONS'	0.05
77420	Brass plate (75 x 75mm) marked 'GAS'	0.05

Specifications

General

The access covers and frames shall be ACO Rhinocast infill access covers with T-frames as manufactured by ACO Pty Ltd. or equal approved.

Materials

The Rhinocast infill access covers and T-frames shall be manufactured from ductile iron (spheroidal graphite cast iron) to the requirements of AS 3996 with:

Minimum tensile strength: 600MPa
Minimum elongation: 3%

The cover and frames shall be coated with a black water based paint for short term protection only.

Cover

The Rhinocast infill covers with reduced ribs allow for 40mm deep pavers shall have the following features to AS 3996 requirements:

Load Class C (150kN)
Watertight & Gas-tight Sealed
Internal Pressure Resistance IPD
Permanent Markings
Lifting Keyholes

Rhinocast covers are locked down as standard with two stainless steel M12x75 hex head bolts.

Optional, specify if required:

For a more secure cover, specify 'SB' after part number for tamper resistant security

bolts.

Optional, specify if required:

For pavers deeper than 40mm, specify SS / BE* for stainless steel or brass edging, and specify 12mm / 40mm* high edging after the part number.

Installation

The access cover shall be installed in accordance with the manufacturer's installation instructions and recommendations.

* delete as applicable

Rebate Dimensions For Class C

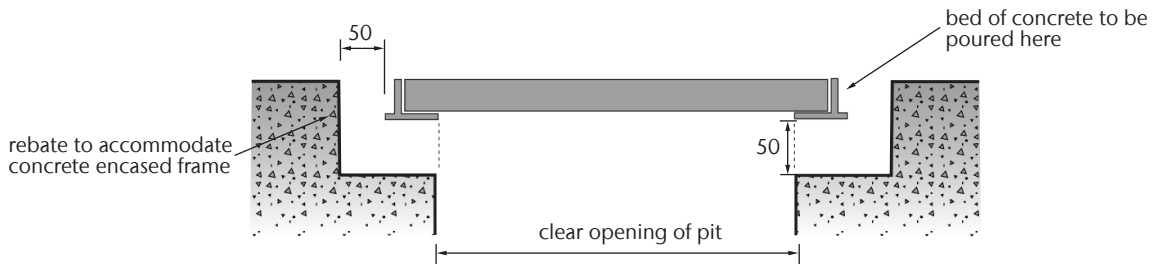

Due to the varying frame dimensions for different covers and decorative edging options, dimensions shown indicate the minimum amount of concrete required around the frame.

Full details at www.acoaccess.com.au/product-support/installation-guidance/

Concrete of a minimum strength of 32MPa and minimum aggregate of 12mm is recommended.



ACO Pty Ltd
Australia

Ph: 1300 765 226
www.acoaus.com.au

